

# REGULATING AND MONITORING

## EFR 012 Electronic Hygrostat



- Adjustable & pre-set relative humidity setpoints
- Compact design
- High switching capacity
- Optical function display (LED)
- DIN rail mountable

The EFR 012 electronic hygrostat senses the relative humidity in an enclosure and turns on a heater at the set point, helping prevent the formation of condensation in the enclosure. The integrated LED is lit when the connected device is in operation.



### Technical Data

Switching difference	5% RH ( $\pm 1\%$ tolerance) - at 77°F (25°C) and 50% RH
Reaction time	approx. 5 seconds
Contact type	SPDT / change-over contact (relay)
Service life	> 100,000 cycles
Max. switching capacity (relay output)	8A resistive / 1.6A inductive @ 120VAC 8A resistive / 1.6A inductive @ 240VAC 4A @ 24VDC
EMC	acc. to EN 55014-1-2, EN 61000-3-2, EN 61000-3-3
Connection	5-pole terminal, clamping torque 0.5Nm max.: solid wire - AWG 14 max. (2.5mm <sup>2</sup> ) stranded wire (with wire end ferrule) - AWG 16 max. (1.5mm <sup>2</sup> )
Housing	plastic, UL 94V-0, light grey
Mounting	clip for 35mm DIN rail, EN 60 715
Mounting position	vertical
Operating temperature	+32 to +140°F (0 to +60°C)
Storage temperature	-4 to +176°F (-20 to +80°C)
Max. storage humidity	90% RH (non-condensing)
Dimensions	2.54 x 1.65 x 1.5" (64.5 x 42 x 38mm)
Weight	approx. 2.3 oz. (65g)
Protection type	IP20

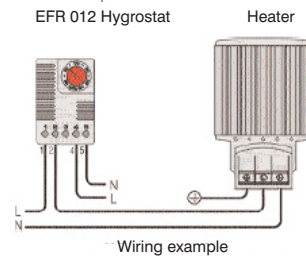
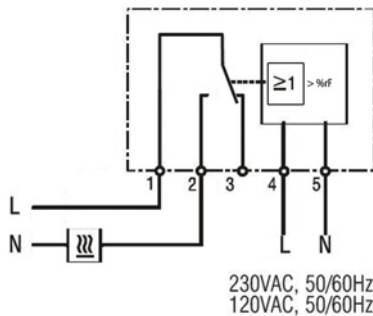
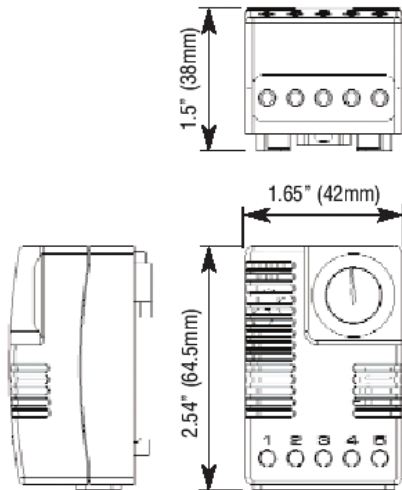

Part No.	Operating voltage	Setting range	Approvals
01245.0-00	230VAC	40 to 90% RH	UL & VDE intended
01245.9-00	120VAC	65% RH pre-set	UL intended
01246.0-00	230VAC	40 to 90% RH	UL & VDE intended
01246.9-00	120VAC	65% RH pre-set	UL intended

Data subject to change without notice.

# REGULATING AND MONITORING

## ETF 012 Electronic Hygrotherm



- **Efficient temperature & humidity control**
- **Wide adjustment ranges**
- **High switching capacity**
- **Optical function displays (LED)**
- **DIN rail mountable**

The ETF 012 senses the ambient temperature and relative air humidity. Depending on which contact combination is chosen, it then turns on or off a connected device if either the temperature is below, or the humidity above the set point. The integrated LED in each adjustment knob is lit when indicating the active function.



### Technical Data

Switching difference - temperature	3.6°F (2K) ± 1K tolerance - at 77°F (25°C) and 50% RH
Switching difference - humidity	4% RH ± 1% tolerance - at 77°F (25°C) and 50% RH
Response time - humidity	approx. 5 sec.
Contact type	SPDT / change-over contact (relay)
Contact resistance	< 10mΩ
Service life	NC: > 50,000 cycles NO: > 100,000 cycles
Max. switching capacity	NC: 6A resistive / 1A inductive @ 120VAC NO: 8A resistive / 1.6A inductive @ 120VAC NC: 6A resistive / 1A inductive @ 240VAC NO: 8A resistive / 1.6A inductive @ 240 VAC 4A @ 24VDC
EMC	acc. to EN 55014-1-2, EN 61000-3-2, EN 61000-3-3
Connection	5-pole terminal, clamping torque 0.5Nm max.: solid wire - AWG 14 max. (2.5mm <sup>2</sup> ) stranded wire (with wire end ferrule) - AWG 16 max. (1.5mm <sup>2</sup> )
Housing	plastic, UL 94V-0, light grey
Mounting	clip for 35mm DIN rail, EN 60 715
Mounting position	vertical
Operating temperature	+32 to +140°F (0 to +60°C)
Storage temperature	-4 to +176°F (-20 to +80°C)
Dimensions	3.0 x 2.4 x 1.7" (77 x 60 x 43mm)
Weight	approx. 7 oz. (200g)
Protection type	IP20

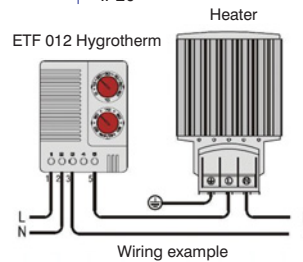
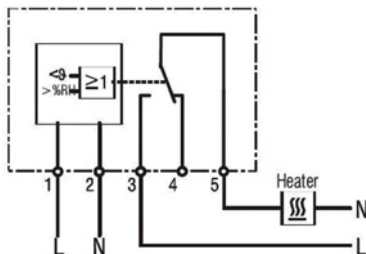
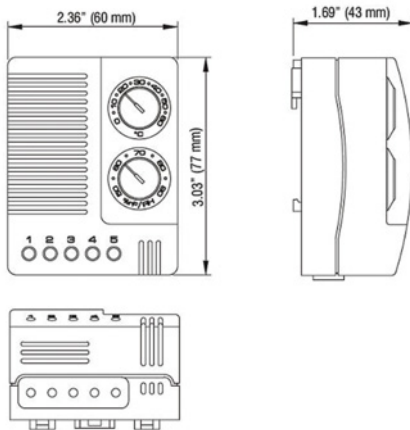

Part No.	Operating voltage	Setting range - temperature	Setting range - humidity	Approvals
01230.0-00	230VAC, 50/60Hz	0 to 60°C	50 to 90% RH	UL File No. E164102, VDE
01230.9-00	120VAC, 50/60Hz	32 to 140°F	50 to 90% RH	UL File No. E164102
01230.9-01	120VAC, 50/60Hz	0 to 60°C	50 to 90% RH	UL File No. E164102

Data subject to change without notice.



# REGULATING AND MONITORING

## MFR 012 Mechanical Hygrostat



- **Efficient condensation control**
- **Adjustable relative humidity range**
- **High switching capacity**
- **DIN rail mountable**

The MFR 012 electromechanical thermostat is designed to control the relative humidity inside enclosures. When connected to an enclosure heater (dehumidifier), it will energize the heater at the humidity set point in order to raise the dew point. This helps prevent damage and malfunction of electronic components caused by condensation and corrosion.<sup>1)</sup>

The MFR 012 can also be used to control cooling fans, warning lights or other devices.



### Technical Data

<b>Switching difference</b>	4% RH (± 3% tolerance) - at 50% RH
<b>Permissible air velocity</b>	50 ft/sec (15m/s)
<b>Contact type</b>	SPDT / change-over contact
<b>Contact resistance</b>	< 10mΩ
<b>Service life</b>	> 100,000 cycles
<b>Min. Switching capacity</b>	100mA @ AC/DC 20V
<b>Max. Switching capacity</b>	5A resistive / 1A inductive @ 250VAC
	DC 20W
<b>EMC</b>	acc. to EN 55014-1-2, EN 61000-3-2, EN 61000-3-3
<b>Connection</b>	3-pole terminal, clamping torque 0.5Nm max.:
	solid wire - AWG 14 max. (2.5mm <sup>2</sup> )
	stranded wire (with wire end ferrule) - AWG 16 max. (1.5mm <sup>2</sup> )
<b>Housing</b>	plastic, UL 94V-0, light grey
<b>Mounting</b>	clip for 35mm DIN rail, EN 60 715
<b>Mounting position</b>	vertical
<b>Operating temperature</b>	+32 to +140°F (0 to +60°C)
<b>Storage temperature</b>	-4 to +176°F (-20 to +80°C)
<b>Dimensions</b>	2.64 x 1.97 x 1.5" (67 x 50 x 38mm)
<b>Weight</b>	approx. 2 oz. (60g)
<b>Protection type</b>	IP20
<b>Approvals</b>	UL File No. 164102

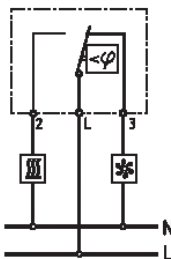
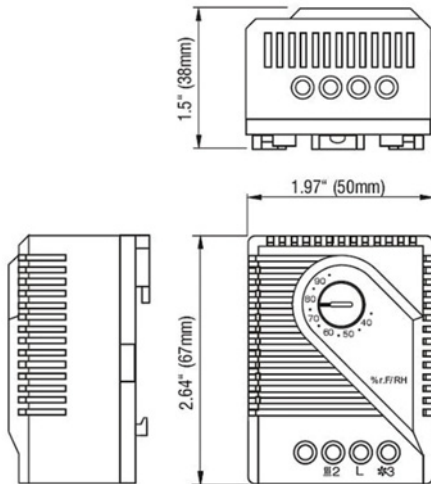

Enclosure heater

Filter fan, cooling equipment, signal device

<sup>1)</sup> The critical relative humidity level for most components is 65%. Above 65% RH, condensation can form and cause malfunctions of electronic equipment. Long term, this can lead to corrosion and permanent damage of electronic components and systems.

Data subject to change without notice.

<b>Part No.</b>	<b>Setting range</b>
01220.0-00	35 to 95% RH

# REGULATING AND MONITORING

## FT 011 Tamperproof Thermostat



**Compact design**

**Fixed setpoints**

**Color coded modules**

**DIN rail mountable**

### Tamperproof (Pre-set) Thermostat FTO 011

NC / opens on temperature rise (**red** module housing) - for regulating heaters or for switching signal devices when temperature has fallen below the minimum value.

### Tamperproof (Pre-set) Thermostat FTS 011

NO / closes on temperature rise (**blue** module housing) - for regulating filter fans, heat exchangers, cooling devices or for switching signal devices when temperature limit has been exceeded.



### Technical Data

Sensor element	thermostatic bimetal
Contact type	snap-action contact
Contact resistance	< 20mΩ
Service life	> 100,000 cycles
Max. switching capacity	10A resistive / 2A inductive @ 120VAC 5A resistive / 1.6A inductive @ 240VAC
Max. inrush current	DC 30W AC 10A
EMC	acc. to EN 55014-1-2, EN 61000-3-2, EN 61000-3-3
Connection	2-pole terminal for AWG 14 max. (2.5mm <sup>2</sup> ), torque 0.8Nm max.
Housing	plastic, UL 94V-0, light grey
Mounting	clip for 35mm DIN rail, EN 60 715
Mounting position	vertical
Operating temperature	-4 to +176°F (-20 to +80°C)
Storage temperature	-49 to +176°F (-45 to +80°C)
Dimensions	1.85 x 1.3 x 1.3" (47 x 33 x 33mm)
Weight	approx. 0.8 oz. (23g)
Protection type	IP20
Approvals	UL File No. E164102, VDE

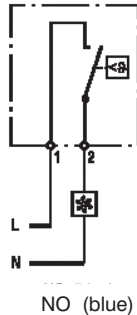
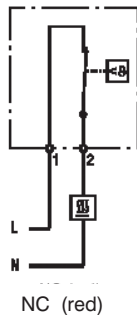
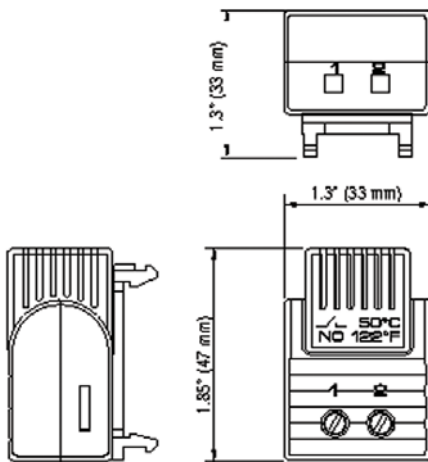

Heater FTO 011 Thermostat FTS 011 Thermostat e.g. Fan FTS 011 Thermostat e.g. Signal Device

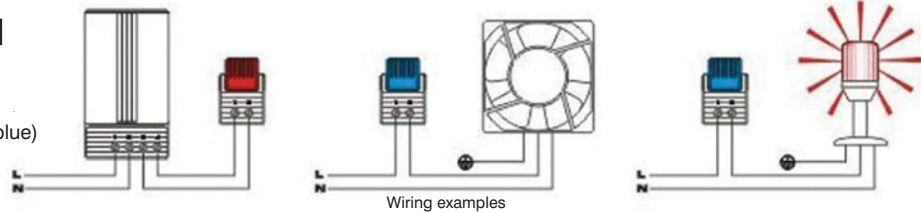

Part No.	Contact	Switch-off temperature	Switch-on temperature
01160.0-00	NC - open on rise	59°F / 15°C (± 9°F / 5K tolerance)	41°F / 5°C (± 9°F / 5K tolerance)
01160.0-01	NC - open on rise	77°F / 25°C (± 9°F / 5K tolerance)	59°F / 15°C (± 9°F / 5K tolerance)
		Switch-on temperature	Switch-off temperature
01161.0-00	NO - close on rise	122°F / 50°C (± 11°F / 6K tolerance)	104°F / 40°C (± 12.6°F / 7K tolerance)
01161.0-01	NO - close on rise	140°F / 60°C (± 11°F / 6K tolerance)	122°F / 50°C (± 12.6°F / 7K tolerance)
01161.0-02	NO - close on rise	95°F / 35°C (± 11°F / 6K tolerance)	77°F / 25°C (± 12.6°F / 7K tolerance)

Data subject to change without notice.



# REGULATING AND MONITORING

## KT 011 Small Thermostat



- **Compact design**
- **Wide adjustment range**
- **Color coded temperature dials**
- **DIN rail mountable**

### Thermostat NC (normally closed)

Thermostat opens on temperature rise - for regulating heaters or for switching signal devices. Comes with **red** temperature dial.

### Thermostat NO (normally open)

Thermostat closes on temperature rise - for regulating filter fans and heat exchangers or for switching signal devices. Comes with **blue** temperature dial.



### Technical Data

<b>Switching difference</b>	12.6°F ± 7°F tolerance (7K ± 4K)
<b>Sensor element</b>	thermostatic bimetal
<b>Contact type</b>	snap-action contact
<b>Contact resistance</b>	< 10mΩ
<b>Service life</b>	> 100,000 cycles
<b>Max. switching capacity</b>	15A resistive / 2A inductive @ 120VAC 10A resistive / 2A inductive @ 250VAC
	DC 30W
<b>Minimum load</b>	20mA (all voltages)
<b>EMC</b>	acc. to EN 55014-1-2, EN 61000-3-2, EN 61000-3-3
<b>Connection</b>	2-pole terminal, clamping torque 0.5Nm max.: solid wire - AWG 14 max. (2.5mm <sup>2</sup> ) stranded wire (with wire end ferrule) - AWG 16 (1.5mm <sup>2</sup> )
<b>Housing</b>	plastic, UL 94V-0, light grey
<b>Mounting</b>	clip for 35mm DIN rail, EN 60 715 (or for Exhaust Filter EF 118 Series)
<b>Mounting position</b>	vertical
<b>Operating / Storage temperature</b>	-49 to +176°F (-45 to +80°C)
<b>Dimensions</b>	2.4 x 1.3 x 1.7" (60 x 33 x 43mm)
<b>Weight</b>	approx. 1.4 oz. (40g)
<b>Protection type</b>	IP20

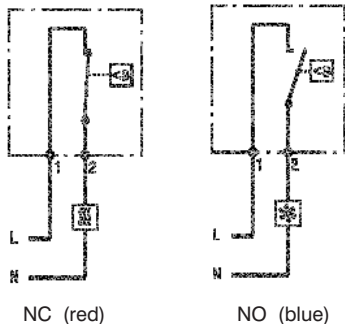
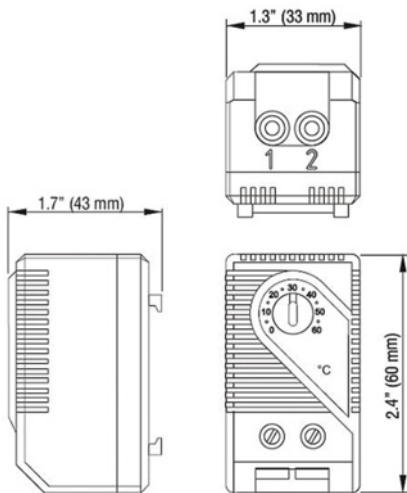

KT 011 Thermostat Heater      KT 011 Thermostat e.g. Fan      KT 011 Thermostat e.g. Signal Device

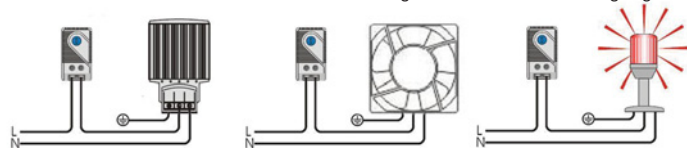

Wiring examples

Setting range	Part No. (NC)	Part No. (NO)	Approvals
+32 to +140°F	01140.9-00	01141.9-00	UL File No. E164102, CSA
0 to +60°C	01146.9-00	01147.9-00	UL File No. E164102, CSA
-10 to +50°C	01142.0-00	N/A	UL File No. E164102, CSA, VDE
+10 to +70°C	N/A	01149.9-00	UL File No. E164102, CSA
-15 to +45°C	01157.0-00	01156.0-00	UL File No. E164102, CSA
+20 to +80°C	01159.0-00	01158.0-00	UL File No. E164102, CSA, VDE

Data subject to change without notice.

# REGULATING AND MONITORING

## FTD 011 Tamperproof Dual Thermostat



**NC / NO or NO / NO in one unit**

**Fixed setpoints**

**Color coded modules**

**DIN rail mountable**

**Two thermostats in one housing:**

### Tamperproof (Pre-set) Thermostat - NC

Opens on temperature rise (**red** module housing) - for regulating heaters or for switching signal devices when temperature has fallen below the minimum value.

### Tamperproof (Pre-set) Thermostat - NO

Closes on temperature rise (**blue** module housing) - for regulating filter fans, heat exchangers, cooling devices or for switching signal devices when temperature limit has been exceeded.

Heaters and cooling equipment can be switched independently from each other with a temperature offset as opposed to the usual SPDT/change-over contact.



### Technical Data

Sensor element	thermostatic bimetal
Contact type	snap-action contact
Contact resistance	< 20mΩ
Service life	> 100,000 cycles
Max. switching capacity	10A resistive / 2A inductive @ 120VAC 5A resistive / 1.6A inductive @ 240VAC DC 30W
Max. inrush current	AC 10A
EMC	acc. to EN 55014-1-2, EN 61000-3-2, EN 61000-3-3
Connection	4-pole terminal for AWG 14 max. (2.5mm <sup>2</sup> ), torque 0.8Nm max.
Housing	plastic according to UL 94V-0, light grey
Mounting	clip for 35mm DIN rail, EN 60 715
Mounting position	vertical
Operating temperature	-4 to +176°F (-20 to +80°C)
Storage temperature	-49 to +176°F (-45 to +80°C)
Dimensions	1.85 x 2.5 x 1.3" (47 x 63 x 33mm)
Weight	approx. 14.1 oz. (40g)
Protection type	IP20
Approvals	UL File No. E164102, VDE

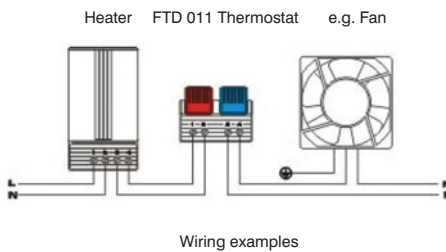
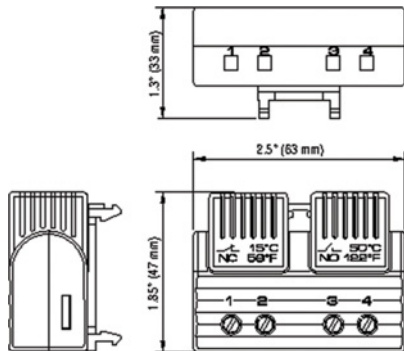

Part No.	NC - open on rise		NO - close on rise	
	Switch-off temperature	Switch-on temperature	Switch-on temperature	Switch-off temperature
01163.0-00	59°F / 15°C (± 9°F / 5K tolerance)	41°F / 5°C (± 9°F / 5K tolerance)	122°F / 50°C (± 11°F / 6K tolerance)	104°F / 40°C (± 12.6°F / 7K tolerance)
01163.0-01	77°F / 25°C (± 9°F / 5K tolerance)	59°F / 15°C (± 9°F / 5K tolerance)	140°F / 60°C (± 11°F / 6K tolerance)	122°F / 50°C (± 12.6°F / 7K tolerance)
01163.0-02	59°F / 15°C (± 9°F / 5K tolerance)	41°F / 5°C (± 9°F / 5K tolerance)	95°F / 35°C (± 11°F / 6K tolerance)	77°F / 25°C (± 12.6°F / 7K tolerance)
01163.0-03	77°F / 25°C (± 9°F / 5K tolerance)	59°F / 15°C (± 9°F / 5K tolerance)	122°F / 50°C (± 11°F / 6K tolerance)	104°F / 40°C (± 12.6°F / 7K tolerance)
Part No.	NO - close on rise		NO - close on rise	
	Switch-on temperature	Switch-off temperature	Switch-on temperature	Switch-off temperature
01164.0-00	122°F / 50°C (± 11°F / 6K tolerance)	104°F / 40°C (± 12.6°F / 7K tolerance)	140°F / 60°C (± 11°F / 6K tolerance)	122°F / 50°C (± 12.6°F / 7K tolerance)

Data subject to change without notice.



# REGULATING AND MONITORING

## ZR 011 Dual Thermostat



- **NC / NO or NO / NO in one unit**
- **Separate adjustable temperatures**
- **Color coded temperature dials**
- **DIN rail mountable**

The ZR 011 houses two separate thermostats, allowing the independent control of heating and cooling or other equipment.

### Thermostat NC (normally closed):

Thermostat opens at temperature rise - for regulating heaters or for switching signal devices. Comes with **red** temperature dial.

### Thermostat NO (normally open):

Thermostat closes at temperature rise - for regulating filter fans and heat exchangers or for switching signal devices. Comes with **blue** temperature dial.



### Technical Data

Switching difference	12.6°F ± 7°F tolerance (7K ± 4K tolerance)
Sensor element	thermostatic bimetal
Contact type	snap-action contact
Contact resistance	< 10mΩ
Service life	> 100,000 cycles
Max. switching capacity	NC: 10A resistive / 2A inductive at 250VAC NO: 5A resistive / 2A inductive @ 250VAC DC 30W
EMC	acc. to EN 55014-1-2, EN 61000-3-2, EN 61000-3-3
Connection	4-pole terminal, clamping torque 0.5Nm max.: solid wire - AWG 14 max. (2.5mm <sup>2</sup> ) stranded wire (with wire end ferrule) - AWG 16 max. (1.5mm <sup>2</sup> )
Housing	plastic, UL 94V-0, light grey
Mounting	clip for 35mm DIN rail, EN 60 715
Mounting position	vertical
Operating / Storage temperature	-49 to +176°F (-45 to +80°C)
Dimensions	2.6 x 2.0 x 1.8" (67 x 50 x 46mm)
Weight	approx. 3.2 oz. (90g)
Protection type	IP20
Approvals	UL File No. E164102, CSA

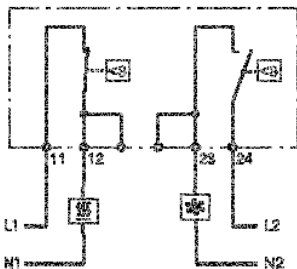
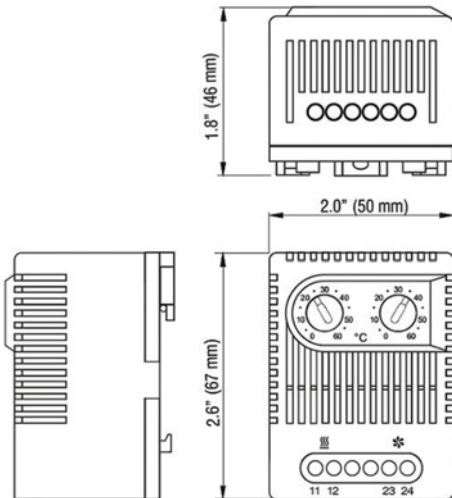

- Enclosure heater
- Filter fan, cooling equipment, signal device

Data subject to change without notice.

Part No.	Setting Range	Setting Range	Setting Range	Setting Range
01172.0-00	NC - open on rise	0 to +60°C	NO - close on rise	0 to +60°C
01172.0-01	NC - open on rise	+32 to +140°F	NO - close on rise	+32 to +140°F
01175.0-00	NC - open on rise	-10 to +50°C	NO - close on rise	+20 to +80°C
01175.0-01	NC - open on rise	14 to +122°F	NO - close on rise	+68 to +176°F
01176.0-00	NO - close on rise	0 to +60°C	NO - close on rise	0 to +60°C
01176.0-01	NO - close on rise	+32 to +140°F	NO - close on rise	+32 to +140°F

# REGULATING AND MONITORING

## FZK 011 Mechanical Thermostat



**Wide adjustment range**

**High switching capacity**

**SPDT (Change-over) contact**

**DIN rail mountable**

The FZK 011 mechanical thermostat is used for controlling heating and cooling equipment, filter fans or signal devices where a higher degree of sensing accuracy is required. An integrated resistor (RF) can be connected to improve the switch temperature difference.<sup>2)</sup>

The thermostat registers the surrounding air and can switch both inductive and resistive loads via snap-action contact.



### Technical Data

<b>Switching difference</b>	approx. 7°F (4K), ± 2.7°F (1.5K) tolerance <sup>1)</sup>
<b>Sensor element</b>	thermostatic bimetal
<b>Contact type</b>	SPDT / change-over contact
<b>Contact resistance</b>	< 10mΩ
<b>Service life</b>	> 100,000 cycles
<b>Max. switching capacity, NC</b>	10A resistive / 4A inductive @ 120VAC 10A resistive / 4A inductive @ 250VAC DC 30W
<b>Max. switching capacity, NO</b>	5A resistive / 2A inductive @ 120VAC 5A resistive / 2A inductive @ 250VAC DC 30W
<b>EMC</b>	acc. to EN 55014-1-2, EN 61000-3-2, EN 61000-3-3
<b>Connection</b>	4-pole terminal, clamping torque 0.5Nm max.: solid wire - AWG 14 max. (2.5mm <sup>2</sup> ) stranded wire (with wire end ferrule) - AWG 16 max. (1.5mm <sup>2</sup> )
<b>Housing</b>	plastic, UL 94V-0, light grey
<b>Mounting</b>	clip for 35mm DIN rail, EN 60 715
<b>Mounting position</b>	vertical
<b>Operating temperature</b>	-4 to +176°F (-20 to +80°C)
<b>Storage temperature</b>	-49 to +176°F (-45 to +80°C)
<b>Dimensions</b>	2.64 x 1.97 x 1.5" (67 x 50 x 38mm)
<b>Weight</b>	approx. 3.5 oz. (100g)
<b>Protection type</b>	IP20

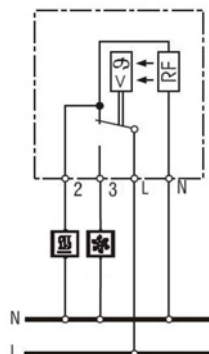
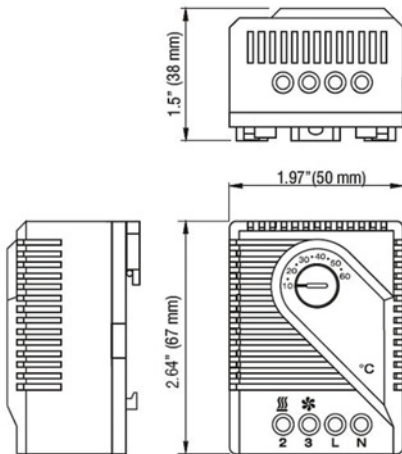

Enclosure heater  
 Filter fan, cooling equipment, signal device

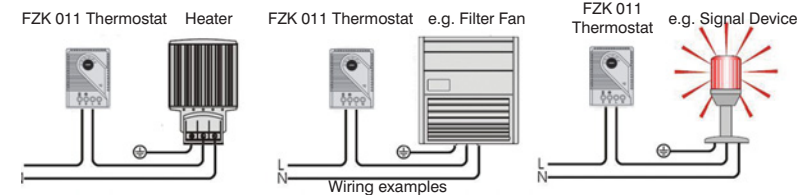

<sup>1)</sup> Connecting terminal "N" (RF heating resistor) causes the thermal feedback to work, reducing the switch temperature difference to approx. 1°F (0.5K).

Part No.	Operating voltage <sup>2)</sup>	Setting range	Approvals
01170.0-00	230VAC	5 to 60°C	UL File No. E164102
01170.0-01	230VAC	40 to 140°F	UL File No. E164102
01170.9-00	120VAC	40 to 140°F	UL File No. E164102
01170.9-01	120VAC	5 to 60°C	UL File No. E164102

<sup>2)</sup> Voltage only needs to be specified if the optional use of the RF resistor is desired.

Data subject to change without notice.



# REGULATING AND MONITORING

## ET 011 Electronic Thermostat (24VDC)

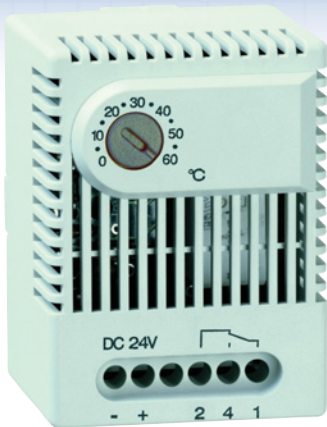

- **16 Amp DC switching capacity**
- **Low hysteresis**
- **Wide adjustment range**
- **DIN rail mountable**

The ET 011 is an electronic thermostat for regulating high performance DC 24V equipment. Heating or cooling equipment, as well as signal devices, can be switched via the SPDT (change-over) contact.

A relatively small hysteresis sets the ET 011 Thermostat apart from less accurate mechanical thermostats.

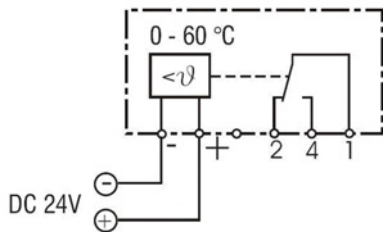
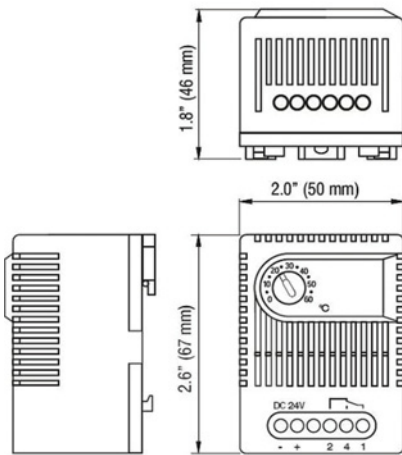

### Technical Data

<b>Switching difference</b>	approx. 5.4°F (3K)
<b>Sensor element</b>	PTC
<b>Contact type</b>	SPDT / change-over contact
<b>Contact resistance</b>	< 10mΩ
<b>Service life</b>	> 100,000 cycles
<b>Max. switching capacity</b>	16A @ 28VDC
<b>EMC</b>	acc. to EN 55014-1-2, EN 61000-3-2, EN 61000-3-3
<b>Connection</b>	5-pole terminal, clamping torque 0.5Nm max.: solid wire - AWG 14 max. (2.5mm <sup>2</sup> ) stranded wire (with wire end ferrule) - AWG 16 max. (1.5mm <sup>2</sup> )
<b>Housing</b>	plastic, UL 94V-0, light grey
<b>Mounting</b>	clip for 35mm DIN rail, EN 60 715
<b>Mounting position</b>	vertical
<b>Operating temperature</b>	+32 to +140°F (0 to +60°C)
<b>Storage temperature</b>	-49 to +176°F (-45 to +80°C)
<b>Dimensions</b>	2.6 x 2.0 x 1.8" (67 x 50 x 46mm)
<b>Weight</b>	approx. 2.8 oz. (80g)
<b>Protection type</b>	IP20

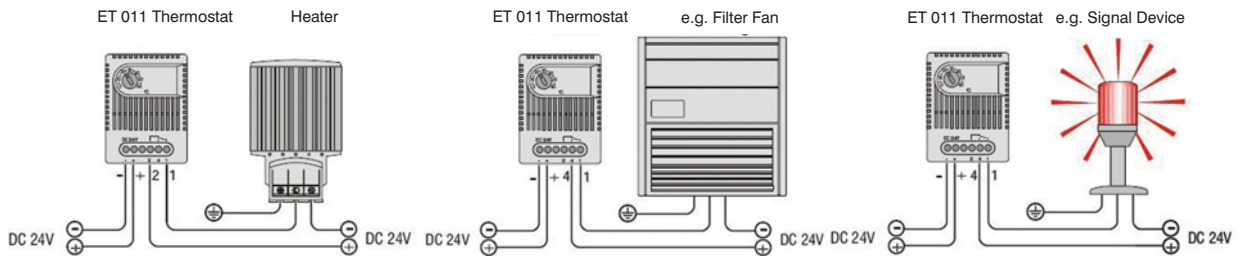

Wiring examples

Part No.	Operating voltage	Setting range
01190.0-00	24VDC (20-28VDC)	0 to 60°C
01190.0-01	24VDC (20-28VDC)	32 to 140°F

Data subject to change without notice.

# REGULATING AND MONITORING

## SM 010 Electronic Relay (24VDC & 48VDC)



- 16 Amp DC switching capacity
- Variety of applications
- Compact design
- DIN rail mountable

The SM 010 Electronic Relay is used for switching high powered DC operated equipment, such as heaters, up to 16 amps. A separate conventional switch contact is used as controller (e.g. thermostat, hygrosstat). The electronic relay is available in 24VDC and 48VDC versions.

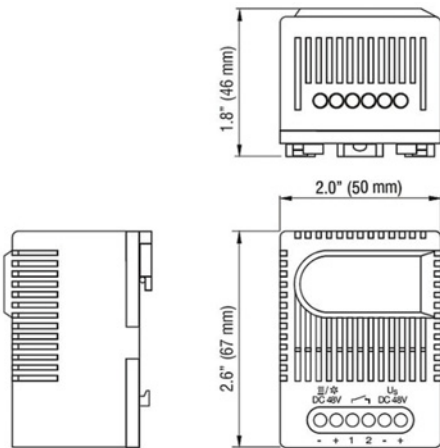

### Technical Data

<b>Contact type</b>	NO - normally open (Relay/MOSFET)
<b>Contact resistance</b>	< 10mΩ
<b>Service life</b>	> 100,000 cycles
<b>EMC</b>	acc. to EN 55014-1-2, EN 61000-3-2, EN 61000-3-3
<b>Connection</b>	6-pole terminal, clamping torque 0.5Nm max.: solid wire - AWG 14 max. (2.5mm <sup>2</sup> ) stranded wire (with wire end ferrule) - AWG 16 (1.5mm <sup>2</sup> )
<b>Housing</b>	plastic, UL 94V-0, light grey
<b>Mounting</b>	clip for 35mm DIN rail, EN 60 715
<b>Mounting position</b>	vertical
<b>Operating / Storage temperature</b>	-49 to +158°F (-45 to +70°C)
<b>Dimensions</b>	2.6 x 2.0 x 1.8" (67 x 50 x 46mm)
<b>Weight</b>	approx. 3.0 oz. (85g)
<b>Protection type</b>	IP20
<b>Approvals</b>	VDE intended

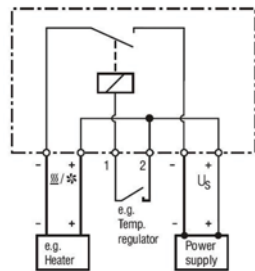

**Load**, e.g. heater, cooling device with temperature limiter

**SM 010 Electronic relay**

**Control contact**, e.g. thermostat, hygrosstat, or pressure regulator

**Load**, e.g. heater, cooling device without temperature limiter

**SM 010 Electronic relay**

**Control contact**, e.g. thermostat, hygrosstat, or pressure regulator

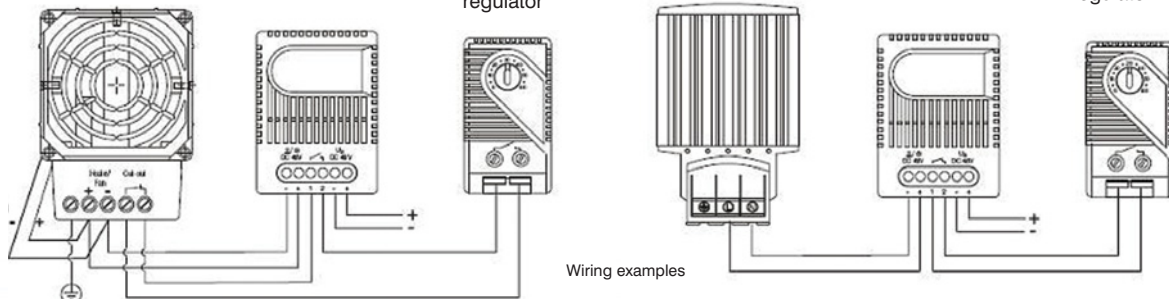

Wiring examples

Part No.	Operating voltage	Max. Switching capacity
01000.0-00	48VDC (38-56VDC)	16A @ 56VDC
01001.0-00	24VDC (20-28VDC)	16A @ 28VDC

Data subject to change without notice.



# REGULATING AND MONITORING

## REx 011 Explosion-proof Thermostat



- **Compact design**
- **Fixed temperature setpoints**
- **High switching capacity**
- **DIN rail mountable**

The design of the REx 011 thermostat ensures high accuracy, small switching difference (hysteresis) and a long service life.

Because of the high switching capacity of the thermostat, heaters can usually be directly connected and switched without the need for additional relays.

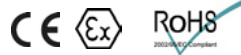

### Technical Data

<b>Explosion proof according to EN</b>	LCIE (Laboratoire Central des Industries Electriques)
<b>Conformity certificate</b>	01 ATEX 6074/02, LCIE N°06 ATEX Q8011, IECEx LCI 07. 0021
<b>Sensor element</b>	thermostatic bimetal
<b>Contact type</b>	opens on temperature rise
<b>Service life</b>	> 100,000 cycles
<b>Max. switching capacity</b>	4A resistive / 1A inductive @ 250VAC
<b>Connection</b>	Si HF - JZ 3 x AWG 18 (0.75mm <sup>2</sup> ), length 3.3 ft (1m)
<b>Housing</b>	aluminum, black anodized
<b>Mounting</b>	mounting bracket with M8 nut and clip for 35mm DIN rail
<b>Mounting position</b>	variable
<b>Operating temperature</b>	-4 to +104°F (-20 to +40°C)
<b>Storage temperature</b>	-49 to +158°F (-45 to +70°C)
<b>Weight</b>	approx. 7 oz. (200g)
<b>Protection class</b>	I (grounded)
<b>Protection type</b>	IP65

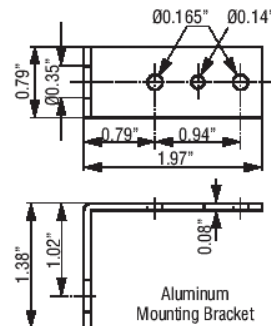
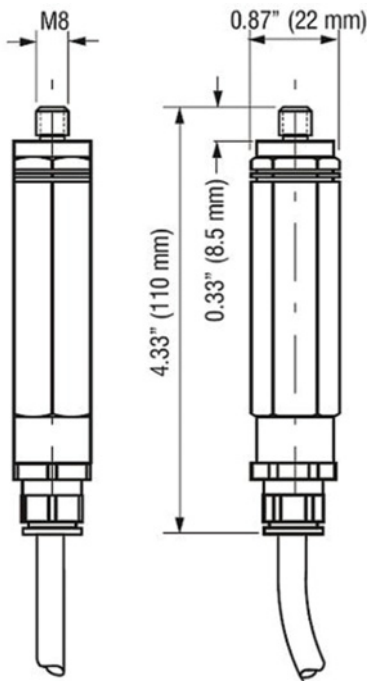

Data subject to change without notice.

Part No.	Ex protection type	Switch-off temperature	Switching difference
01180.0-00	II 2 G D - EEx d IIC T6 IP6x T85°C	59°F ± 7°F tolerance (15°C ± 4K tolerance)	7°F ± 2°F tolerance (4K ± 1K tolerance)
01181.0-00	II 2 G D - EEx d IIC T6 IP6x T85°C	77°F ± 7°F tolerance (25°C ± 4K tolerance)	7°F ± 2°F tolerance (4K ± 1K tolerance)