

## Right flange mounted disconnect multi-door enclosure

The 9500 UxD oil and dust tight right flange mounted safety disconnect enclosures are used indoors for protection against dirt, dust, oil and water splashing. One, two or three door combinations are available. The 9500 UxD are made from quality code gauge steel with all seams continuously welded. Most center posts can be removed (refer to drawings) to facilitate the installation of the inner panel. The ball bearing pins of the concealed die cast hinges can be

easily pulled out to remove the doors. Three point automotive padlockable handles ensure positive closing on all doors.

The new latching rod system interlocks with the disconnect handle and eliminates the need to purchase an adaptor. A door interlock is installed to ensure that the left hand door(s) (slave) can only be opened if the right hand door (master) is open and the disconnect switch is powered off. Door and body stiffeners are pro-

vided on larger models. **Each enclosure comes complete with a painted white steel inner panel** which mount on M10 welded studs. A print pocket is provided. Enclosures and panels are finished with heat fused polyester powder, electrostatically applied on a phosphatized base. Box is ANSI/ASA 61 gray.

**CSA Certified / UL Listed  
NEMA/EEMAC 12-13 / IP65**

**If the 9500 UxD is to be used with a flange mounted disconnect switch or a circuit breaker, the following items must be ordered:**

### Ordering an Allen-Bradley 1494V Disconnect switch

- an operating mechanism with the disconnect switch 1494V
- an operating handle 1494V-H1
- a connecting rod 1494V-RA1 if the enclosure is 8" deep or 1494V-RA2 if the enclosure is 12" deep
- if required, a trailer fuse block kit 1494V, a fuse clip and line and load connectors.

### Circuit breaker

- a Westinghouse or General Electric circuit breaker.
- an operating mechanism 1494V
- an operating handle 1494V-H11
- a connecting rod 1494V-RA1 if the enclosure is 8" deep or 1494V-RA2 if the enclosure is 12" deep

### Ordering a Cutler Hammer Disconnect switch catalog C361

- an operating mechanism with the disconnect switch
- an operating handle (C361-H2 or H4)

### Circuit breaker operators catalog C371

- a Cutler hammer or Westinghouse circuit breaker
- an operating mechanism
- an operating handle

### Ordering an Asea Brown Boveri Disconnect switches

- a switch flange operated fuse if required
- a DSFHS-12 shaft
- a DSFHN-HS12 handle

### Circuit breaker

- a circuit breaker
- an operating mechanism
- a FHS-12 shaft
- a FHN-HS12 handle

### Ordering a Square D Class 9422 Disconnect switch

- an operating mechanism with the disconnect switch class 9422
- an operating mechanism handle class 9422 Type A-1

### Circuit breaker

- a Square D circuit breaker
- an operating mechanism class 9422
- an operating mechanism handle class 9422 Type A-1

### Ordering an I-T-E Max-FlexTM Disconnect switch

- a basic right hand switch
- a fuse kit if required
- a handle FHOHS flange mounted
- an operator FHOSO6R
- a cable FHOECO36

### Circuit breaker

- a circuit breaker
- a set of pressure wire connectors
- a handle FHOH flange mounted
- an operating mechanism
- a standard cable 36"

### Ordering a General Electric Disconnect Switches

- a disconnect switch QMR or QMW
- a fuse clip kit if required
- a TDAI flange handle
- an operating mechanism, variable depth

### Circuit breakers

- a circuit breaker
- a TDAI flange handle
- an operating handle 1494V-H11
- an operating mechanism, variable depth

### Ordering a Westinghouse

- a disconnect switch or circuit breaker type DS
- a yoke assembly and backplate
- a rod and brace assembly
- a pivot mechanism
- an operating handle



Data subject to change without notice.

**Disconnect switches and operating mechanisms are not furnished with the enclosures.**



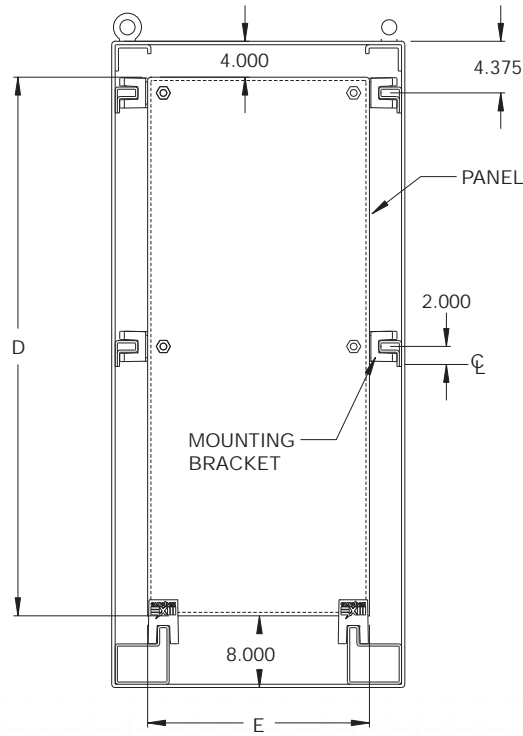
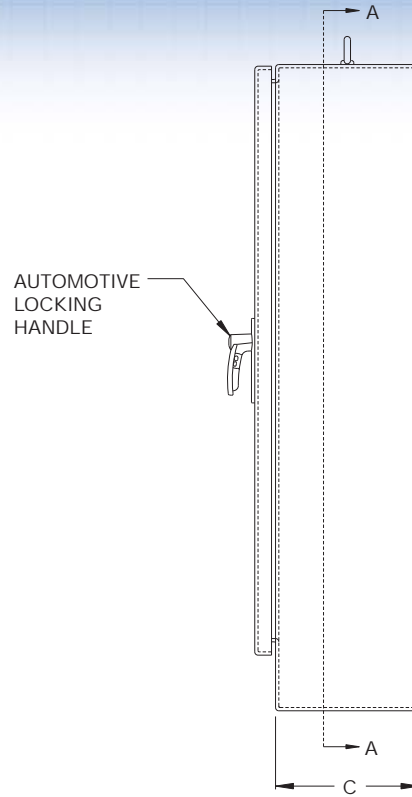
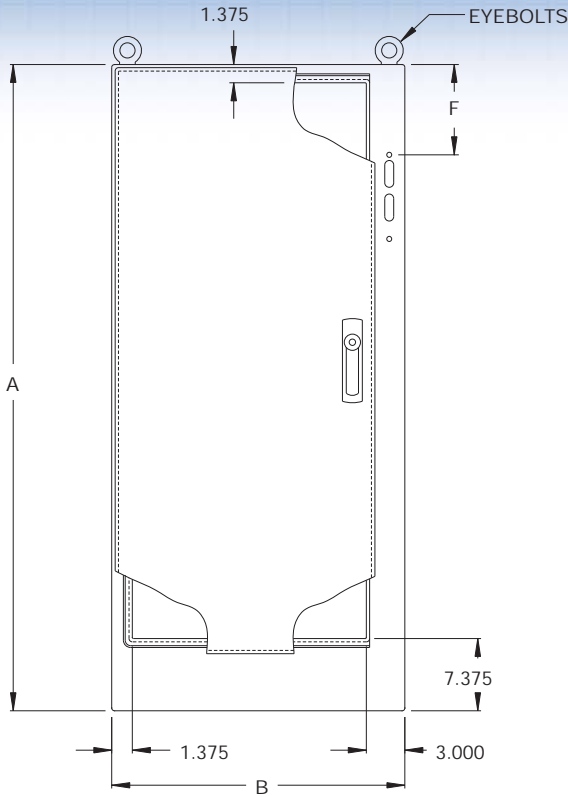

SECTION A-A

CATALOG NUMBER	DIMENSIONS						SHIP WGHT LBS.
	A	B	C	D	E	F	
9500 U1D722818	72	27.5	18	60	21.750	11.875	426
9500 U1D723418	72	33.5	18	60	27.750	11.875	492
9500 U1D724018	72	39.5	18	60	33.750	11.875	558
9500 U1D844018	84	39.5	18	72	33.750	17.875	641
9500 U1D904018	90	39.5	18	78	33.750	20.875	707
9500 U1D904020	90	39.5	20	78	33.750	20.875	725
9500 U1D844024	84	39.5	24	72	33.750	17.875	689
9500 U1D904024	90	39.5	24	78	33.750	20.875	755

\* For Allen Bradley Bulletin 1494F and 1494D disconnect switch piercings, add suffix 'AB' to the catalog number.  
 (Example: 9500 U1D723418AB)  
 Custom piercings are available upon request.

Data subject to change without notice.



p.518

<http://www.exmweb.com>



p.524



p.536



p.494



p.462

1-800-363-2423

Fax : 450-979-4626



[info@exmweb.com](mailto:info@exmweb.com)



# NEMA 12-13 SAFETY DISCONNECT

# 9500 U3D

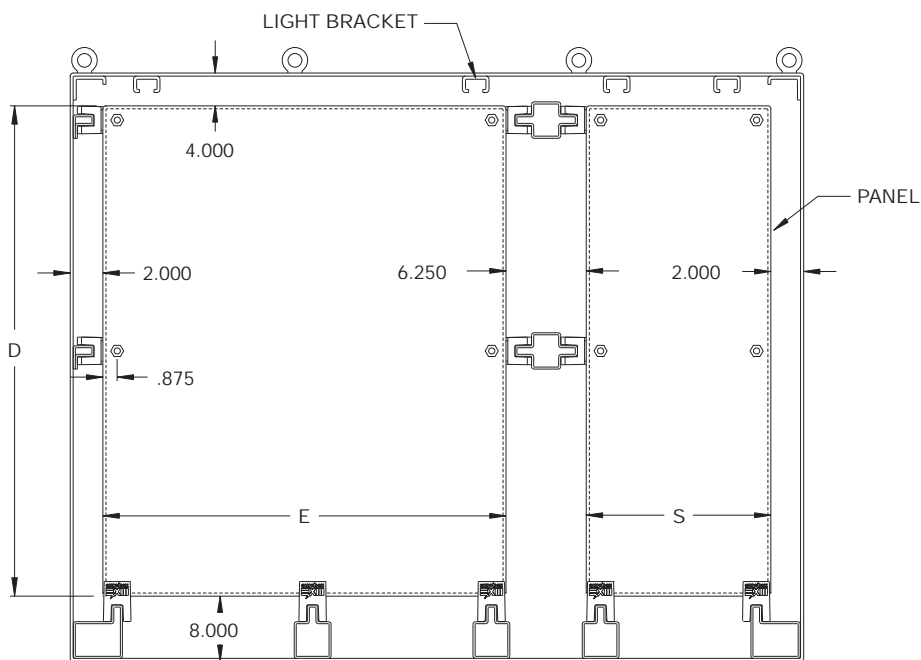
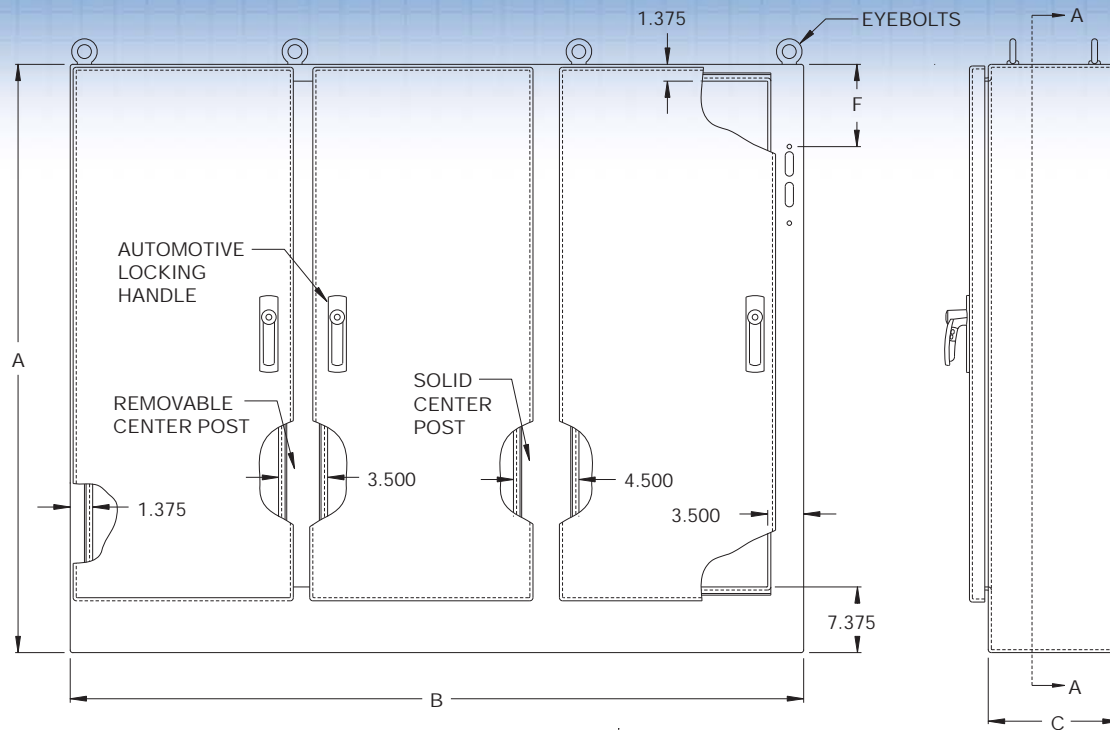

SECTION A-A

\* For Allen Bradley Bulletin 1494F and 1494D disconnect switch piercings, add suffix 'AB' to the catalog number. (Example: 9500 U3D7210018AB)  
Custom piercings are available upon request.

CATALOG NUMBER	DIMENSIONS							SHIP WGT LBS.
	A	B	C	D	E	S	F	
9500 U3D7210018	72	99.500	18	60	60	27.750	11.875	1255
9500 U3D7211818	72	117.500	18	60	72	33.750	11.875	1483
9500 U3D8411818	84	117.500	18	72	72	33.750	17.875	1711
9500 U3D8411824	84	117.500	24	72	72	33.750	17.875	1826
9500 U3D9011824	90	117.500	24	78	72	33.750	20.875	1940

Data subject to change without notice.



p.518

<http://www.exmweb.com>



p.524



p.536



p.494



p.462

1-800-363-2423

Fax : 450-979-4626



[info@exmweb.com](mailto:info@exmweb.com)