

Dual access free standing single door enclosure

The 9500 DA oil & dust tight enclosures are used indoors for protection against dust, dirt or oil splashing. The 9500 DA are made from quality code gauge steel, with corner seams continuously welded. The opening has a curled lip around all sides to prevent dripping water from entering the enclosure when the door is open, it also increases rigidity. A high quality robotically poured-in-

place seamless gasket ensures a complete and durable oil & dust tight seal. There are doors on both sides of the cabinet. The captive pins of the concealed hinges can be pulled to remove the doors. An automotive locking handle ensures smooth, secure 3-point latching. Optional back panels can be mounted at any depth, using the three sets of rails welded on the sides of the cabi-

net. Side panels can also be ordered separately. A print pocket is provided. Enclosures and panels are finished with heat fused polyester powder, electrostatically applied on a pretreated base. Box is ANSI/ASA 61 gray, panel is white (other colors available).

CSA Certified / UL Listed
NEMA/EEMAC 12-13 / IP65

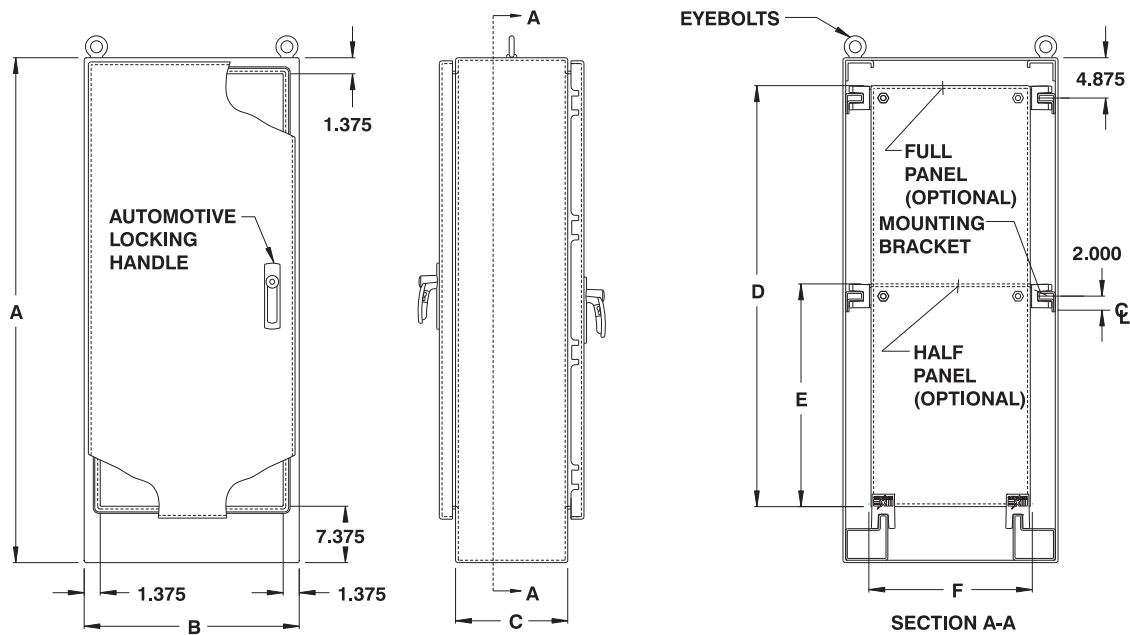

CATALOG NUMBER	DIMENSIONS						EQUIPMENT PANEL		SHIP WGHT LBS.
	A	B	C	D	E	F	FULL	HALF	
9500 DA722424	72	24	24	60	30.875	20	889 FP7224	889 HP7224	325
9500 DA723024	72	30	24	60	30.875	26	889 FP7230	889 HP7230	424
9500 DA723624	72	36	24	60	30.875	32	889 FP7236	889 HP7236	474
9500 DA903624	90	36	24	78	39.875	32	889 FP9036	889 HP9036	540
9500 DA722430	72	24	30	60	30.875	20	889 FP7224	889 HP7224	375
9500 DA722436	72	24	36	60	30.875	20	889 FP7224	889 HP7224	425
9500 DA723636	72	36	36	60	30.875	32	889 FP7236	889 HP7236	495
9500 DA903636	90	36	36	78	39.875	32	889 FP9036	889 HP9036	555

Data subject to change without notice.

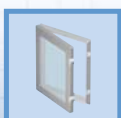

Dual access free standing double door enclosure

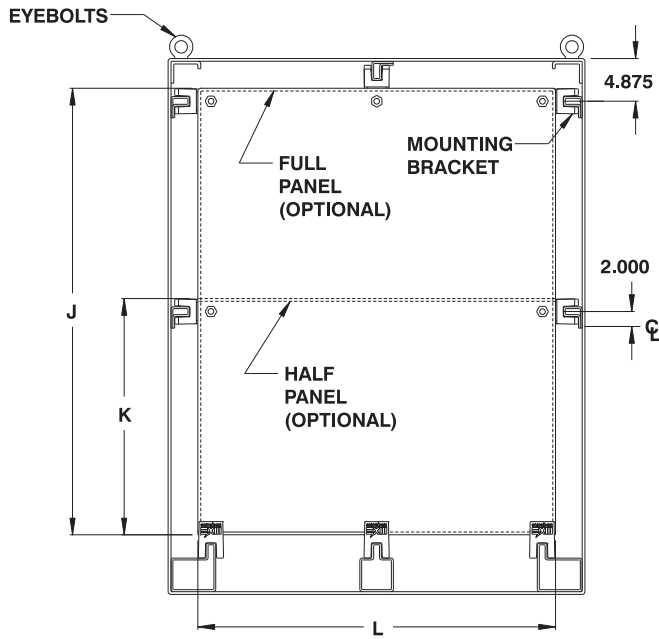
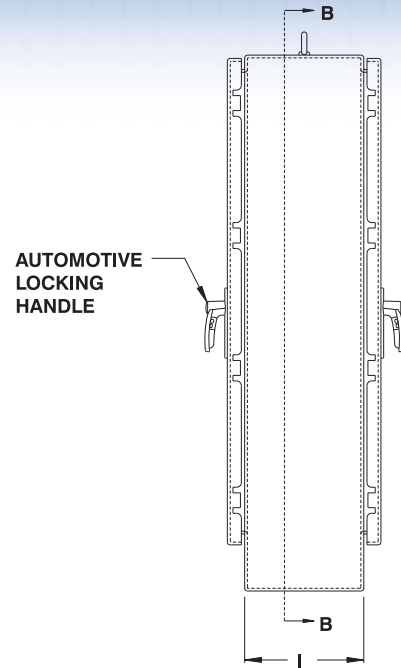
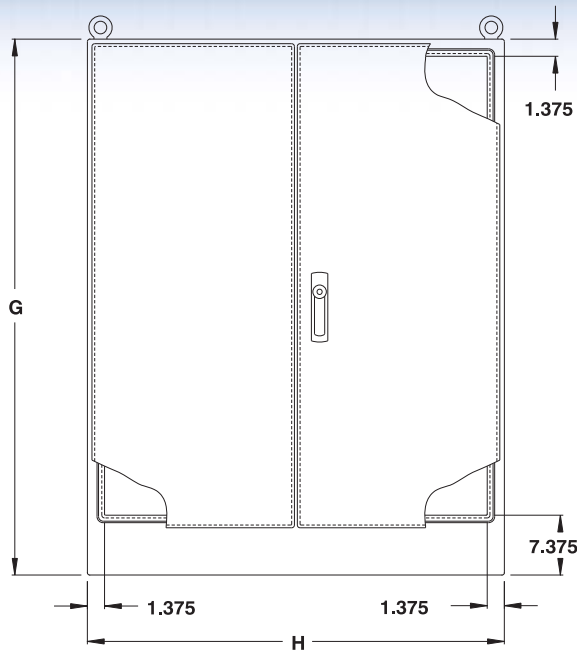

SECTION B-B



CATALOG NUMBER	DIMENSIONS						EQUIPMENT PANEL		SHIP WGHT LBS.
	G	H	I	J	K	L	FULL	HALF	
9500 DA724824	72	48	24	60	30.875	44	889 FP7248	889 HP7248	502
9500 DA726024	72	60	24	60	30.875	56	889 FP7260	889 HP7260	595
9500 DA727224	72	72	24	60	30.875	68	889 FP7272	889 HP7272	649
9500 DA907224	90	72	24	78	39.875	68	889 FP9072	889 HP9072	767
9500 DA726036	72	60	36	60	30.875	56	889 FP7260	889 HP7260	725

Data subject to change without notice.



p.461

<http://www.exmweb.com>



p.463



p.466



p.484

1-800-363-2423

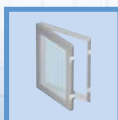

p.479



p.494

Fax : 450-979-4626



p.462



info@exmweb.com