

Oil & dust tight free standing single door enclosure

The 9500 oil & dust tight enclosures are used indoors for protection against dust, dirt or oil splashing. The 9500 are made from quality code gauge steel, with corner seams continuously welded. The opening has a curled lip around all sides to prevent dripping water from entering the enclosure when the door is open, it also increases rigidity. A high quality robotically poured-in-

place seamless gasket ensures a complete and durable oil & dust tight seal. The captive pins of the concealed hinges can be pulled to remove the door. An automotive locking handle ensures smooth, secure 3-point latching. Optional back panels can be mounted at any depth, using the three sets of rails welded on the sides of the cabinet. Side panels can also be ordered separately.

A print pocket is provided. Double door enclosures have stiffeners to the back. Enclosures and panels are finished with heat fused polyester powder, electrostatically applied on a pretreated base. Box is ANSI/ASA 61 gray, panel is white (other colors available).

CSA Certified / UL Listed
NEMA/EEMAC 12-13 / IP65

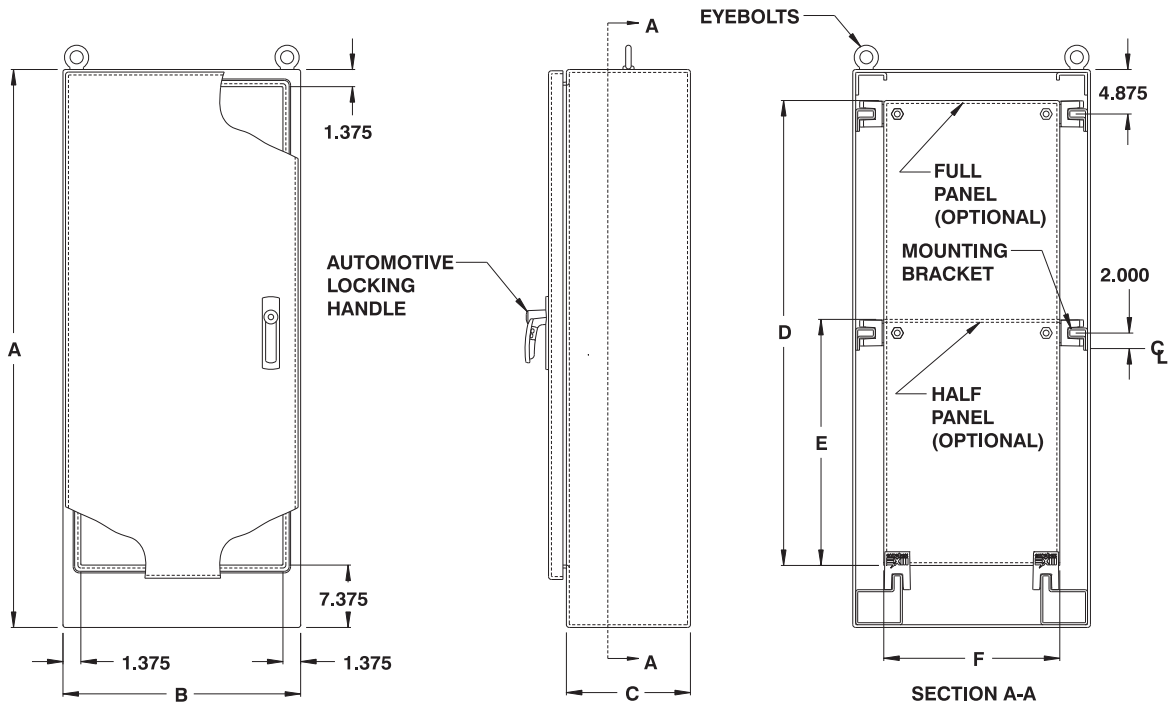

CATALOG NUMBER	DIMENSIONS						EQUIPMENT PANEL		SHIP WGT LBS.
	A	B	C	D	E	F	FULL	HALF	
9500 602418	60	24	18	48	24.875	20	889 FP6024	889 HP6024	250
9500 722418	72	24	18	60	30.875	20	889 FP7224	889 HP7224	280
9500 723018	72	30	18	60	30.875	26	889 FP7230	889 HP7230	300
9500 723618	72	36	18	60	30.875	32	889 FP7236	889 HP7236	330
9500 902420	90	24	20	78	39.875	20	889 FP9024	889 HP9024	405
9500 903620	90	36	20	78	39.875	32	889 FP9036	889 HP9036	440
9500 603624	60	36	24	48	24.875	32	889 FP6036	889 HP6036	300
9500 722424	72	24	24	60	30.875	20	889 FP7224	889 HP7224	300
9500 723024	72	30	24	60	30.875	26	889 FP7230	889 HP7230	340
9500 723624	72	36	24	60	30.875	32	889 FP7236	889 HP7236	375
9500 903624	90	36	24	78	39.875	32	889 FP9036	889 HP9036	445
9500 722430	72	24	30	60	30.875	20	889 FP7224	889 HP7224	358
9500 723630	72	36	30	60	30.875	32	889 FP7236	889 HP7236	420
9500 722436	72	24	36	60	30.875	20	889 FP7224	889 HP7224	400
9500 723636	72	36	36	60	30.875	32	889 FP7236	889 HP7236	470
9500 903636	90	36	36	78	39.875	32	889 FP9036	889 HP9036	500

Data subject to change without notice.



p.461



p.463



p.466



p.484

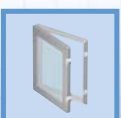

p.479



p.494



p.462

Oil & dust tight free standing double door enclosure

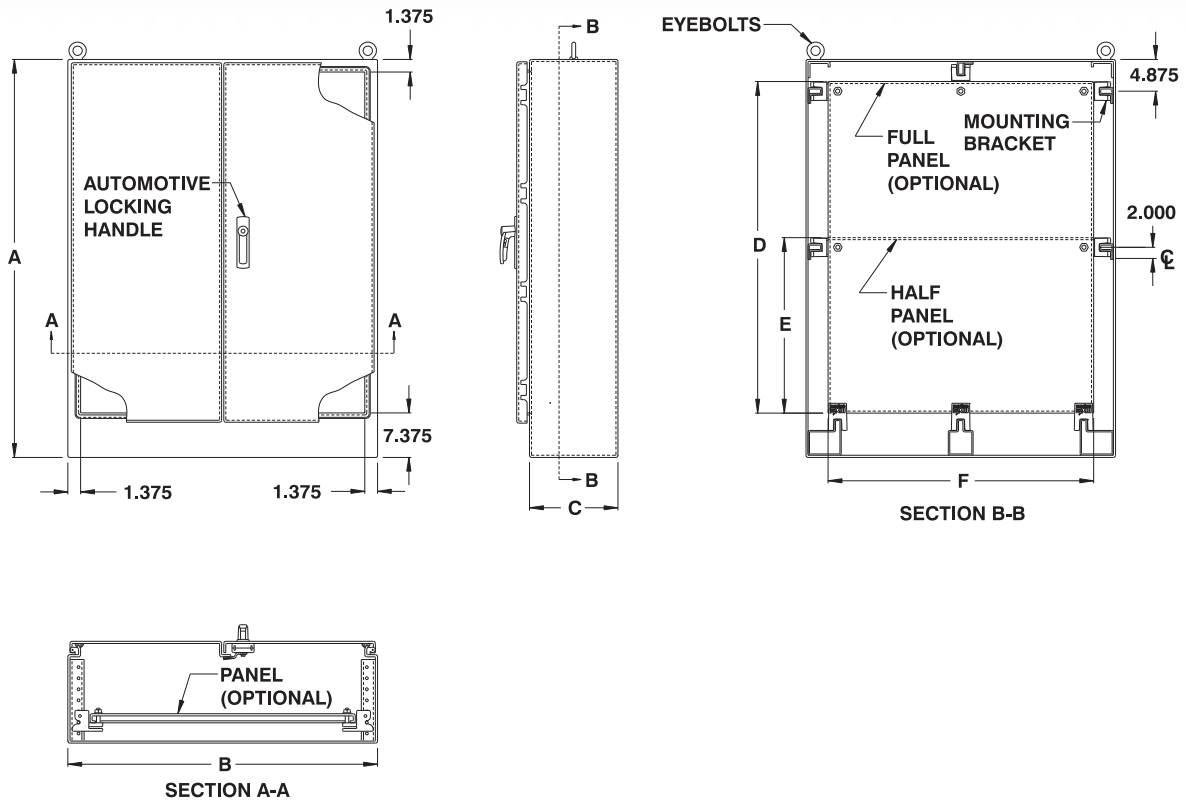

CATALOG NUMBER	DIMENSIONS						EQUIPMENT PANEL		SHIP WGHT LBS.
	A	B	C	D	E	F	FULL	HALF	
9500 604818	60	48	18	48	24.875	44	889 FP6048	889 HP6048	364
9500 724818	72	48	18	60	30.875	44	889 FP7248	889 HP7248	500
9500 726018	72	60	18	60	30.875	56	889 FP7260	889 HP7260	570
9500 727218	72	72	18	60	30.875	68	889 FP7272	889 HP7272	650
9500 904820	90	48	20	78	39.875	44	889 FP9048	889 HP9048	650
9500 907220	90	72	20	78	39.875	68	889 FP9072	889 HP9072	780
9500 724824	72	48	24	60	30.875	44	889 FP7248	889 HP7248	525
9500 726024	72	60	24	60	30.875	56	889 FP7260	889 HP7260	640
9500 727224	72	72	24	60	30.875	68	889 FP7272	889 HP7272	695
9500 907224	90	72	24	78	39.875	68	889 FP9072	889 HP9072	825
9500 726036	72	60	36	60	30.875	56	889 FP7260	889 HP7260	750
9500 907236	90	72	36	78	39.875	68	889 FP9072	889 HP9072	990



Data subject to change without notice.

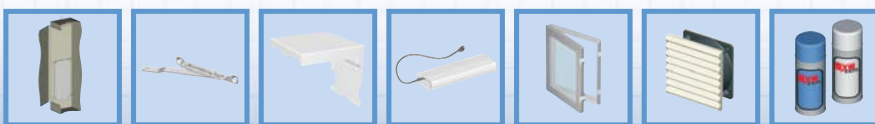

[p.461](#) [p.463](#) [p.466](#) [p.484](#) [p.479](#) [p.494](#) [p.462](#)
<http://www.exmweb.com> 1-800-363-2423 Fax : 450-979-4626



info@exmweb.com