

## Oil & dust tight double door enclosure

The 5500 ESDD wall mounted double door, oil and dust tight enclosures are used indoors for protection against dirt, dust and oil. The box and cover are made from quality 14 GA steel with all seams continuously welded. The opening has a curled lip around all sides and there is no center post.

The left hand door is flanged and the 3-point automotive type locking handle is on the right hand door. The captive pins of the concealed hinges can be easily pulled to remove the door. Wall mounting feet are optionally available. **Each enclosure comes complete with a 12 GA inner panel** which mounts on welded

M8 studs. Enclosures and panels are finished with heat fused polyester powder, electrostatically applied on a pretreated base. Box is ANSI/ASA 61 gray, panel is white.

**CSA Certified / UL Listed  
NEMA/EEMAC 12-13 / IP65**

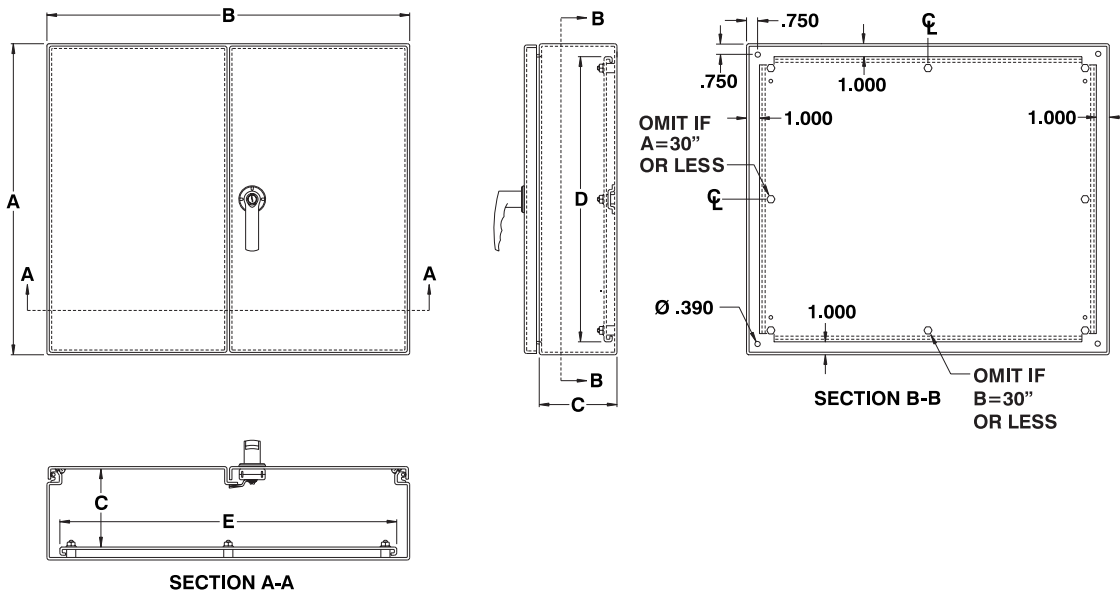

CATALOG NUMBER	DIMENSIONS							SHIP WGT LBS.
	A	B	C	D	E	F	G	
5500 ESDD244208	24	42	8	22	40	25.250	36	117
5500 ESDD244808	24	48	8	22	46	25.250	42	130
5500 ESDD544208	54	42	8	52	40	55.250	36	272
5500 ESDD244210	24	42	10	22	40	25.250	36	150
5500 ESDD304210	30	42	10	28	40	31.250	36	152
5500 ESDD304810	30	48	10	28	46	31.250	42	168
5500 ESDD306010	30	60	10	28	58	31.250	54	203
5500 ESDD364212	36	42	12	34	40	37.250	36	220
5500 ESDD364812	36	48	12	34	46	37.250	42	242
5500 ESDD366012	36	60	12	34	58	37.250	54	292
5500 ESDD424212	42	42	12	40	40	43.250	36	197
5500 ESDD424812	42	48	12	40	46	43.250	42	216
5500 ESDD426012	42	60	12	40	58	43.250	54	349
5500 ESDD484812	48	48	12	46	46	49.250	42	225

Data subject to change without notice.

