

JIC enclosures (light gray)

The **5412 ESCHB** are used indoors or outdoors to protect the enclosed controls from dust, dirt, oil and water splashing. The 5412 ESCHB are made from quality 16 GA steel, with corner seams continuously welded. The opening has a curled lip around all sides to prevent dripping water from entering the enclosure when the door is open, it also increases rigidity. A high quality robotically poured-in-place seamless gasket ensures a complete and durable water tight seal.

The enclosures feature die cast hinges, which are bound to the cover by an exclusive concealed hinge pin system. The covers are interchangeable and can be removed by unfastening the anti-vibration lock nuts.

EXM's exclusive flange-mounted 1/4 turn locking system ensures positive closing while leaving a full workable mounting surface on the door. Each enclosure comes **complete with a 14 GA inner panel** which mounts on weld nuts. The enclosure can be internally mounted or externally

mounted using the included die cast wall mounting feet. These feet have oblong holes to facilitate installation. Enclosures and panels are finished with heat fused polyester powder, electrostatically applied on a pretreated base. Box is RAL7035 textured light gray, panel is white (other colors available).

**CSA Certified / UL Listed
NEMA/EEMAC 4-12 / IP66**

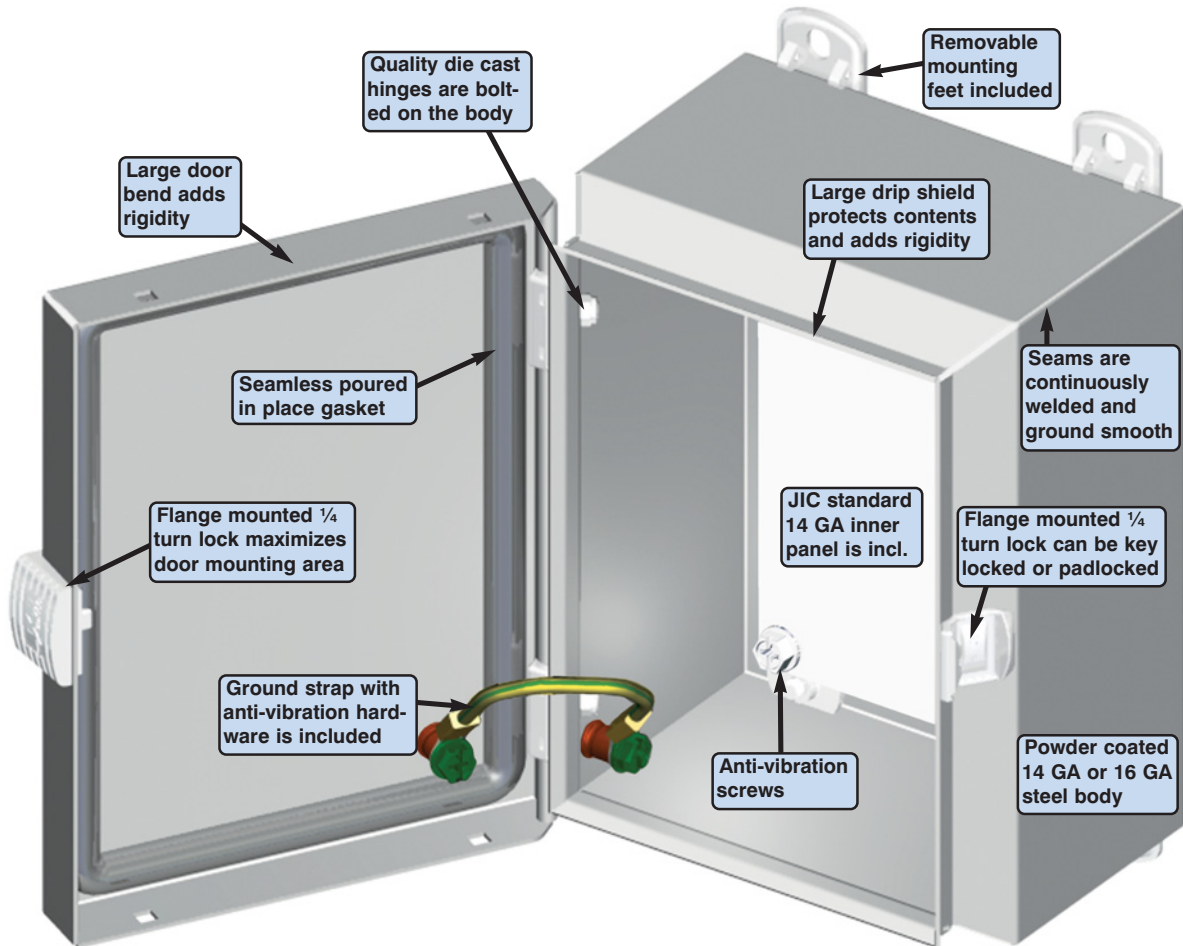

The 5412 ESCHB -
Another EXM innovation

Data subject to change without notice.



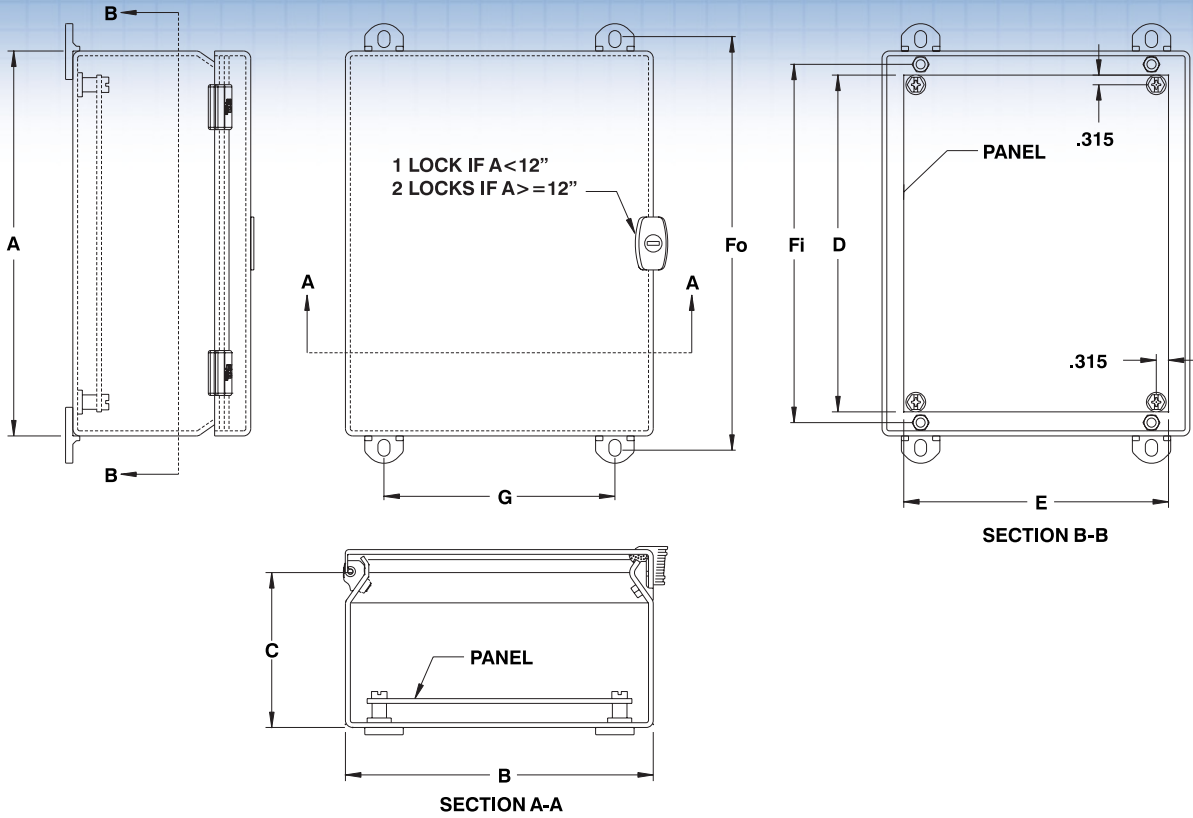

CATALOG NUMBER	DIMENSIONS								SHIP WGHT LBS.
	A	B	C	D	E	Fo	Fi	G	
5412 ESCHB040403	4	4	3	No.Pan.	No.Pan.	4.75	3.312	2	2
5412 ESCHB060403	6	4	3	4.88	2.88	6.75	5.312	2	3
5412 ESCHB060404	6	4	4	4.88	2.88	6.75	5.312	2	4
5412 ESCHB060604	6	6	4	4.88	4.88	6.75	5.312	4	5
5412 ESCHB080604	8	6	4	6.88	4.88	8.75	7.312	4	6
5412 ESCHB080804	8	8	4	6.88	6.88	8.75	7.312	6	8
5412 ESCHB081004	8	10	4	6.88	8.88	8.75	7.312	8	10
5412 ESCHB100804	10	8	4	8.88	6.88	10.75	9.312	6	10
5412 ESCHB120604	12	6	4	10.88	4.88	12.75	11.312	4	8
5412 ESCHB060605	6	6	5	4.88	4.88	6.75	5.312	4	6
5412 ESCHB080605	8	6	5	6.88	4.88	8.75	7.312	4	7
5412 ESCHB101005	10	10	5	8.88	8.88	10.75	9.312	8	14
5412 ESCHB101205	10	12	5	8.88	10.88	10.75	9.312	10	16
5412 ESCHB121005	12	10	5	10.88	8.88	12.75	11.312	8	16
5412 ESCHB121205	12	12	5	10.88	10.88	12.75	11.312	10	18
5412 ESCHB080606	8	6	6	6.88	4.88	8.75	7.312	4	7
5412 ESCHB100806	10	8	6	8.88	6.88	10.75	9.312	6	12
5412 ESCHB101006	10	10	6	8.88	8.88	10.75	9.312	8	14
5412 ESCHB121206	12	12	6	10.88	10.88	12.75	11.312	10	18
5412 ESCHB121406	12	14	6	10.88	12.88	12.75	11.312	12	19
5412 ESCHB140806	14	8	6	12.88	6.88	14.75	13.312	6	10
5412 ESCHB141206	14	12	6	12.88	10.88	14.75	13.312	10	19
5412 ESCHB141606	14	16	6	12.88	14.88	14.75	13.312	14	23
5412 ESCHB161006	16	10	6	14.88	8.88	16.75	15.312	8	19
5412 ESCHB161206	16	12	6	14.88	10.88	16.75	15.312	10	21
5412 ESCHB161406	16	14	6	14.88	12.88	16.75	15.312	12	23
5412 ESCHB121008	12	10	8	10.88	8.88	12.75	11.312	8	16
5412 ESCHB141208	14	12	8	12.88	10.88	14.75	13.312	10	20
5412 ESCHB161208	16	12	8	14.88	10.88	16.75	15.312	10	25
5412 ESCHB161408	16	14	8	14.88	12.88	16.75	15.312	12	26
5412 ESCHB161410	16	14	10	14.88	12.88	16.75	15.312	12	27



Data subject to change without notice.



p.494

p.462

<http://www.exmweb.com>

1-800-363-2423

Fax : 450-979-4626

info@exmweb.com

