

Stainless steel consolets

The 1500 CSS stainless steel consolets are used to protect electrical equipment against dirt, dust, oil and water splashing. The 1500 CSS consolets can be mounted on pedestals (1500 PESS, see page 416), desktops or machines with the choice of a control surface of 35° or 55°. Consolets are made from 16 GA (Type 304) stainless steel with all seams continuously

welded. The cover has a continuous formed hinge. The door is secured by EXM's exclusive flange-mounted quarter-turn locks which ensure positive closing. These locks are also made of stainless steel.

A high quality seamless poured gasket is used to ensure the integrity of the enclosure. Pedestals and base, if required,

must be ordered separately. The consolets' exterior are unpainted and brushed smooth. The consolets' interior are finished with white heat fused polyester powder, electrostatically applied on a phosphatized base.

CSA Certified / UL Listed
NEMA/EEMAC 12-13 / IP65
NEMA/EEMAC 4-12 / IP66 §

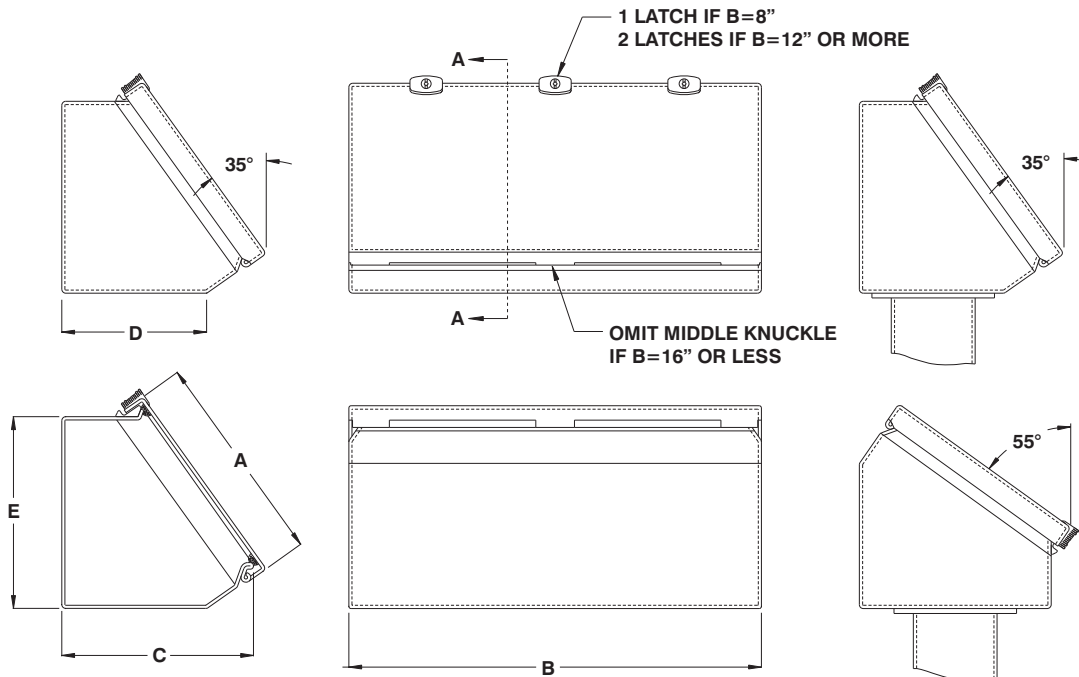

CATALOG NUMBER	DIMENSIONS					SHIP WGHT LBS.
	A	B	C	D	E	
§ 1500 CSS080807	8	8	7.281	5.375	7.437	8
§ 1500 CSS081207	8	12	7.281	5.375	7.437	10
§ 1500 CSS081607	8	16	7.281	5.375	7.437	13
1500 CSS082007	8	20	7.281	5.375	7.437	16
§ 1500 CSS121209	12	12	9.562	7.687	10.718	15
§ 1500 CSS121609	12	16	9.562	7.687	10.718	18
1500 CSS122009	12	20	9.562	7.687	10.718	22
1500 CSS122409	12	24	9.562	7.687	10.718	26
1500 CSS161611	16	16	11.875	9.968	14.000	22
1500 CSS162011	16	20	11.875	9.968	14.000	27
1500 CSS162411	16	24	11.875	9.968	14.000	32
1500 CSS163011	16	30	11.875	9.968	14.000	39
1500 CSS163611	16	36	11.875	9.968	14.000	45
1500 CSS202013	20	20	14.187	12.250	17.250	36
1500 CSS202413	20	24	14.187	12.250	17.250	42
1500 CSS203013	20	30	14.187	12.250	17.250	49



‡ For painted stainless steel, add suffix 'P' to the catalog number (ie. 1500 CSS...P).

Data subject to change without notice.



p.439

<http://www.exmweb.com>



p.482



p.524



p.536

☎ 1-800-363-2423

Fax : 450-979-4626



info@exmweb.com